

Installation requires:

Drill motor, 3/8" chuck
 1/4" rotary burring bit
 3/16", 1/4" & #4 drill bits
 5/32" hex key
 Rat tail file
 Rivet popper
 Phillips screw driver
 Vise grips
 "C" clamps
 3/8" pen end wrench
 1/2" closed end wrench
 Socket set & ratchet
 Tape measure & pencil

This kit Contains:

8010131	Rivet 3/16" x 5/8"	60
8011291	Rivet cap S.S.	60
8060421	Clevis 1/4" x 1 3/16"	4
8031821	Screw, Soc. Set 5/16"-24 x 2"	4
8050331	Nut, 5/16"-24 Hex nylock lo-pro	8
8080891	Washer, 11/16" x 5/16" x .065"	4
68160001	Strut, BLK. Anodized	2
91490021	Kick up bracket	4
8030111	Screw, #10-32 x 1" RHMS	4
8050201	Nut, #10-32 HX Nylock	4
8020061	Clevis pin 3/16" x 13/16"	4
10860001	Clevis pin lock ring, small	4
68190000	Wing leg anchor plate	4
20860005	Clevis pin ring ding, large	4
68950001	Wing cover line, H18 SX 32'	2
68951001	Wing cover line, short 18 x 4'	2
65070001	Mag mount bar 2 1/4"	4
65100000	Strut tab	4
13300001	Anchor plate instruction sheet	1
13290001	Strut instruction sht. insert	1
68130000	H18SX instruction sheet	1
13600001	Tramp lace instruction sheet	1

1. Installation of mounting fasteners

The wings attach and pivot on four socket screws which are threaded into mounting bars inserted into the trampoline track of the front and rear crossbars.

Installation of the mounting fasteners, on pre-1984 boats, requires the enlargement of the trampoline slot so that the socket screws can be threaded into mounting bars. Later boats are pre-drilled.

- A. Remove the trampoline.
- B. On the front crossbar, measure 1 1/4" inward from the inboard hull rail of both hulls.
- C. Using a 1/4" rotary burring bit, or rat tail file, enlarge the trampoline slot to a diameter of 5/16" as shown.
- D. Repeat this procedure on the port side of the rear crossbar.
- E. The starboard side of the rear crossbar has already been routed out to allow for the installation of the trampoline AFT lacing strip and only requires enlargement of the top half. Warning: usage of a standard drill bit to enlarge the trampoline slot is not recommended. Drill bits tend to walk and catch in the slot so use a file instead.
- F. Slide the mounting bars (2 1/4") into the trampoline slot of the front crossbar and the port side of the rear crossbar. Note: it may be necessary to force the mounting bar into the tramp slot or remove some of the material at the opening using a file or rotor burring bit. Only remove enough material required to insert the mounting bar.
- G. Reinstall the AFT lacing strip onto the rear crossbar. Note: it may be necessary to trim some of the bolt rope off of the trampoline corners to allow for clearance of the mounting bars in the tramp slot. Heat sealing the cut edges is recommended (A soldering iron is suitable).
- H. Install the STBD. Mounting ber.
- I. Thread the socket screws into all four mounting bars. Then install anchor plates.
- J. Remove the cover plate from the casting on the crossbars and install the four strut tabs using the outboard assembly bolts on both crossbars. Note: it is recommended that the anti-seize lubricant be applied to the assembly bolts so that the strut tabs can be removed when desired without seizing the bolts. Also, with the bolt removed, it may be necessary to file the opening of the corner casting to remove any sharp burrs and to make sure that the strut tab seats flatly in place.
- K. Reinstall and lace up the trampoline. Again, it may be necessary to trim the ends of the trampoline bolt rope to allow clearance for the mounting bars in the trampoline slot, and the anchor.

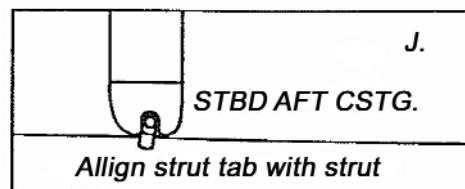
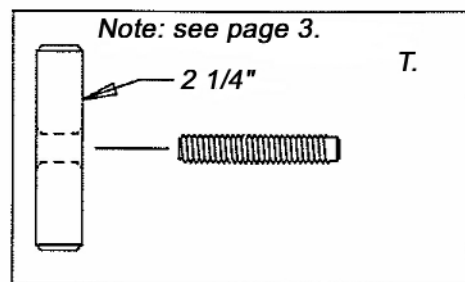
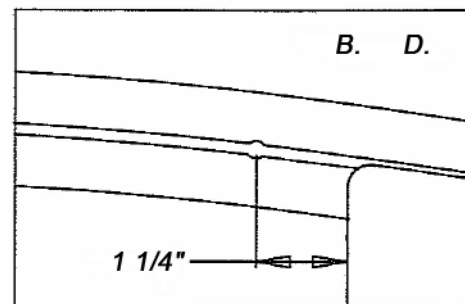

2. Wing Assembly

A. Unpack wing legs and seats from box and identify as follows:

STBD leg AFT	Green sticker marked "A"
STBD leg FWD	Green sticker marked "F"
STBD seat	Green sticker
PORT leg AFT	Red sticker marked "A"
PORT leg FWD	Red sticker marked "F"
PORT seat	Red sticker

B. Place legs in their proper location on the boat and install the remaining washers and nuts.

Warning: Do not overtighten, wing must pivot freely. Also, make sure screws extend past lock nuts a minimum of two to three threads to prevent nuts from backing off. If screws need adjusting to get proper threading. Loosen nuts and adjust with 5/32" hex key.

Note: If the strut of the leg does not cover the bolt head or bear on the casting it may be necessary to bend the strut tab or, in extreme cases, remove the socket screw and lengthen the 5/16" opening to accommodate the variance.

- Once legs are in place, put the seats in position, legs should nest in support casting mounted to the seats. Using "C" clamps, firmly clamp seats to legs in proper position by clamping directly over the support casting as shown.
- Using the castings as drill guides, drill out attachment holes in legs with a #5 drill bit. Install rivets and rivet caps in holes drilled to complete assembly of the wing.
- Remove the wing for trampoline installation.

3. Wing trampoline installation

There are two distinct tramps for the wings, one marked "P" for port and the other "S" for STBD.

Note: For sitting comfort and ease when trapping out from the wings, do not over tighten the tramp or use tools which may damage the tramp material.

- Reinstall wings on boat once tramps are in place.
- With the wing in sailing position, firmly press down on the assembly so that the struts are fitted against the strut tabs and corner casting (covering the bolt head). Be certain that the strut tabs are aligned with the struts.
- Using the strut tab as a drill guide, drill through both walls of the strut with a 1/4" dia. Drill bit. Raise the assembly and clear out debris.
- Secure the wings into position using the four clevis pins and clevis pin ring dings.
- Relead the trapeze wires to the outside of the wings.

Note: to prevent chafing of the tramp material make sure that the clamps on the shockcord are completely close and cover them with tape. Also, a longer shockcord may be needed for preferred trapeze tension.

4. Important operating notes

- Do not exceed the load capacity of 450 pounds.
- When sailing, while sitting on the wings, be aware of the level of the boom because you are much higher than you would be on the trampoline and avoid any accidental jibes (when the mainsail abruptly swings from one side of the boat to the other).
- Remove or cover the strut tabs when sailing without the wings.
- When trailering, it is recommended that you lay the mast sideways.

5. Limited Warranty

Hobie cat warrants that this product is free of defects in materials and workmanship to retail customers in the united states, U.S. possessions and Canada for a period of one year.

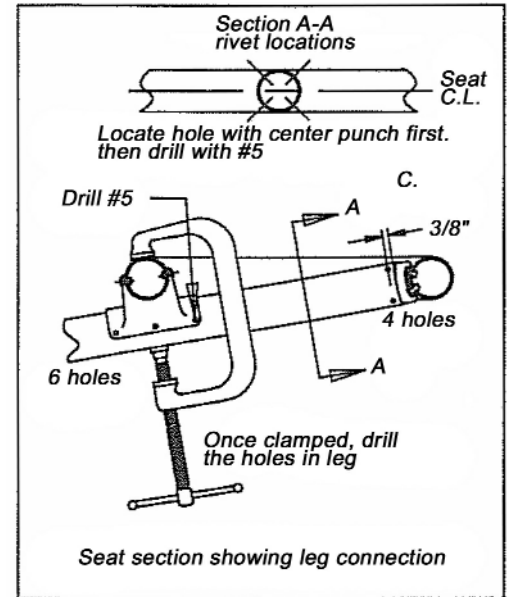

1. Tighten set screw against web in the crossbar.
2. Place anchor plate over set screw, snug into place with nylock nut.
3. Using outer most holes in plate as a drill guide, drill out mount holes with a #4 drill bit on both the top and bottom sides of the crossbar.
4. Install rivets and rivet caps.

Note: Installation is typical for all 4 corners. AFT STBD shown in instructions.

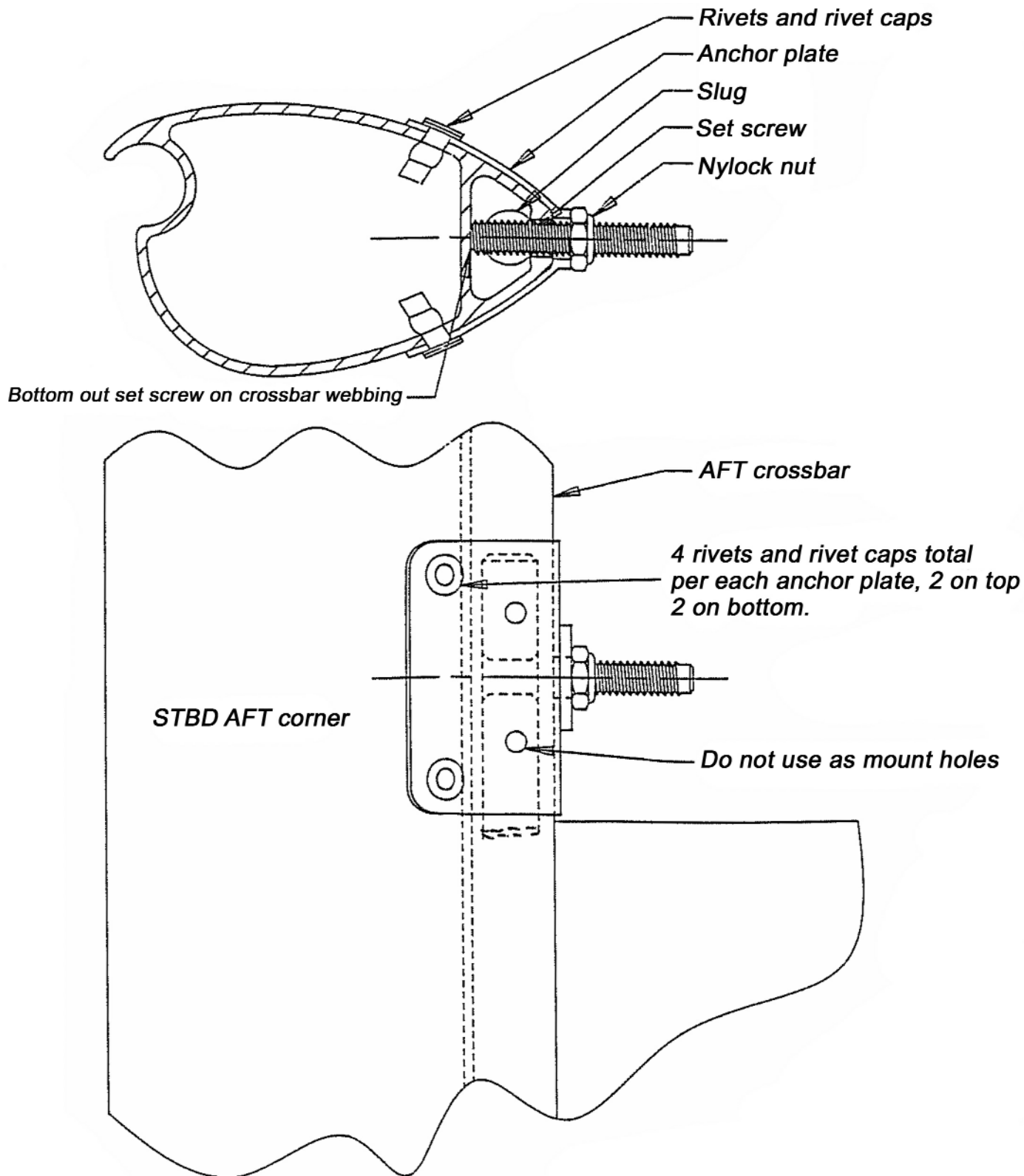

1. Place tramp as shown, depending on which set of wires you have. One of the cut outs on the AFT end will not be used.
2. Secure end of tramp to wind by tying a bowline knot to the end grommet then wrapping two loops around the wind legs and then tying off the line with another bowline knot.
3. Secure opposite end in the same manner, before tightening to remove wrinkles, amke sure trampoline is alligned properly and evenly placed on seat.
4. Begin main lacing as number sequence indicates.
5. For final tramp tension, repeat step 4 and securely tie off.
6. Remove lines used in step 2 and 3 if desired.

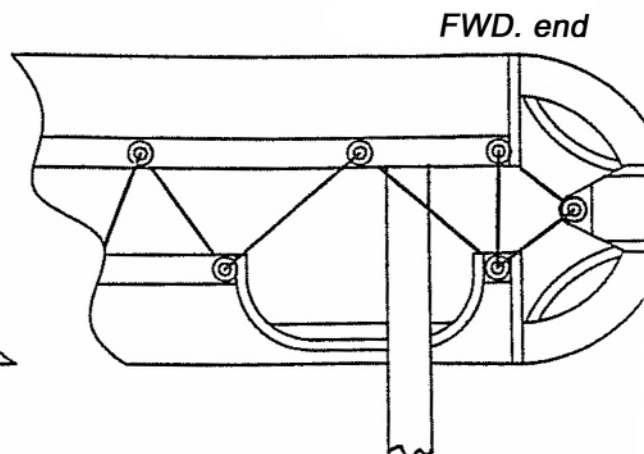
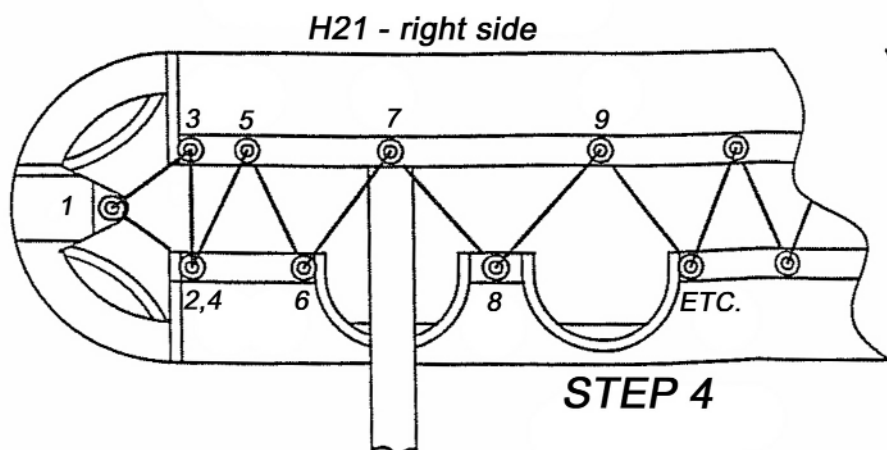
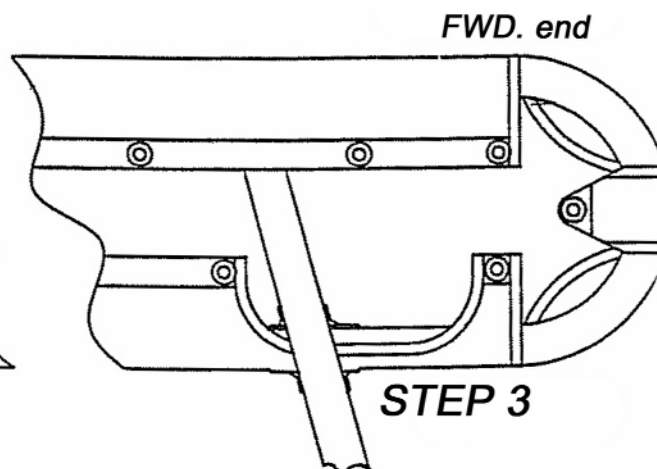
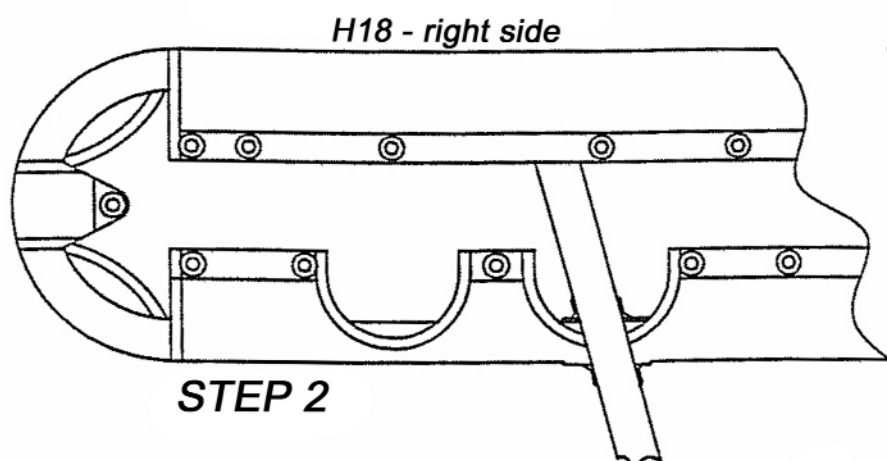

Tools Required:

1. Drill motor, 1/4" chuck
2. #4 drill bit
3. 3/16" drill bit
4. Rivet popper
5. 3/8" open end wrench
6. Phillips screw driver
7. Tape measure
8. 25'-30' of 3/16" MIN. DIA. line
9. Pencil

Instructions:

Note: rudders and wing must be installed for this procedure

1. Place the boat in a position so that the rudders will have ground clearance in both the up and down position. See figure A.1

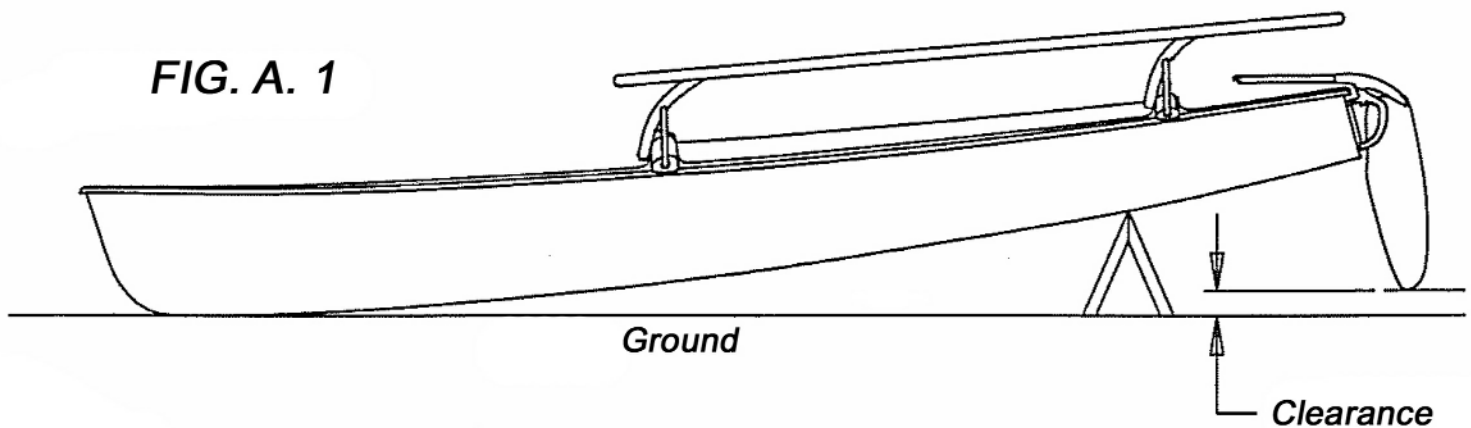

Note: Following instructions are for installing port side strut.

2. Take any FWD/AFT motion out of wing assy. by following instructions in figure A.2

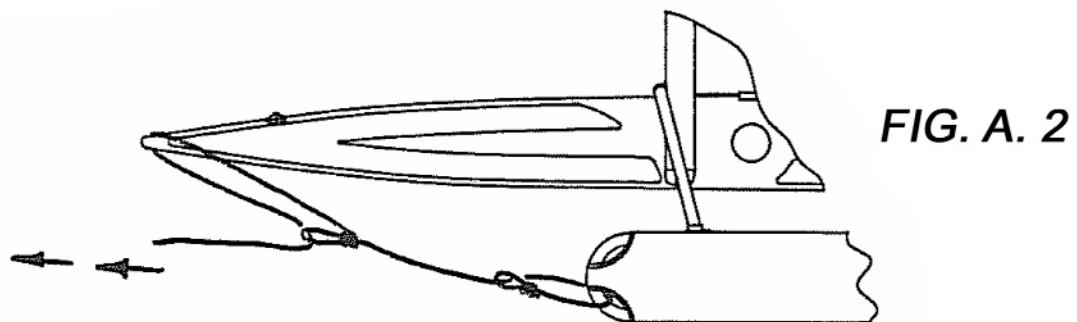

Pull line tight, pulling wing forward to remove play in wing.

3. Drill and mount bracket at given at given dimension of 18 1/4" as shown in figure A.3

FIG. A.3

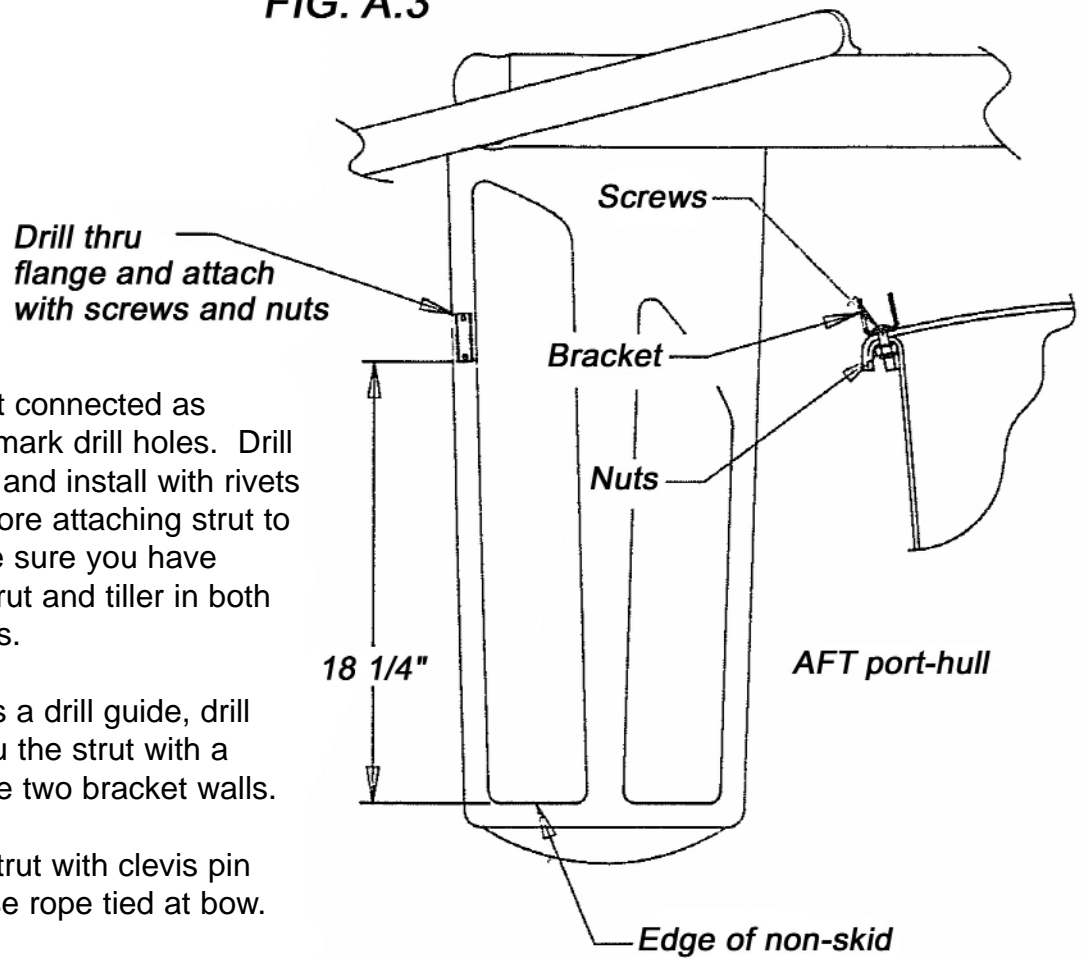

4. Place a strut with bracket connected as shown in figure A. 4 and mark drill holes. Drill out marks with #4 drill bit and install with rivets and rivet caps. Note: before attaching strut to wing leg with rivets, make sure you have clearance between the strut and tiller in both the up and down positions.
5. Using bracket on deck as a drill guide, drill final attachment hole thru the strut with a 3/16" dia. drill bit thru the two bracket walls.
6. Attach lower bracket to strut with clevis pin and ring ding, then release rope tied at bow.
7. Repeat procedure for STBD side.

FIG. A. 4

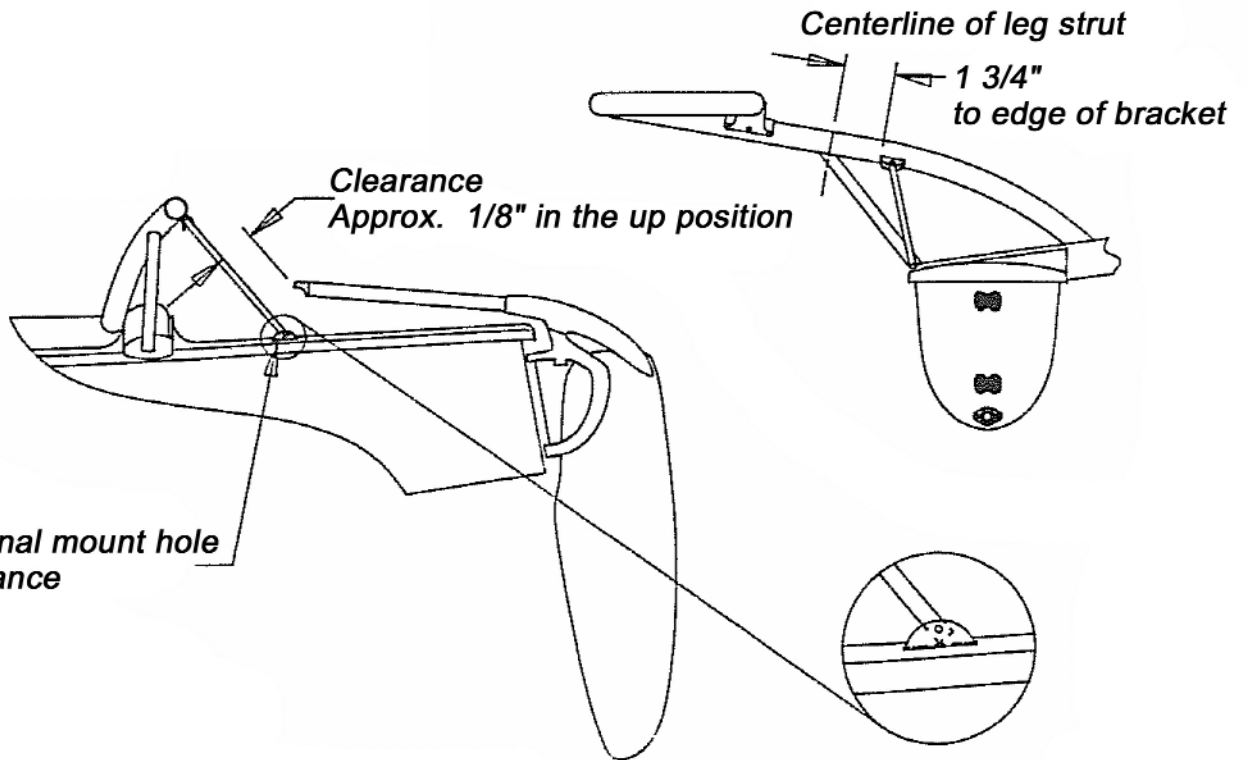

Before drilling final mount hole check the clearance