

Die cast gudgeon installation for Hobie 18 fits newer style (post 87') castings only

Parts - 1 Gudgeon, 1 rudder pin, 2 cotter keys, 3 washers

The die cast gudgeons were designed by Hobie Cat France. These gudgeons have a slightly different mount hole pattern and require that the original eight holes be plugged and eight new holes be drilled and tapped. Plug the old holes with Marine tex or resin with filler.

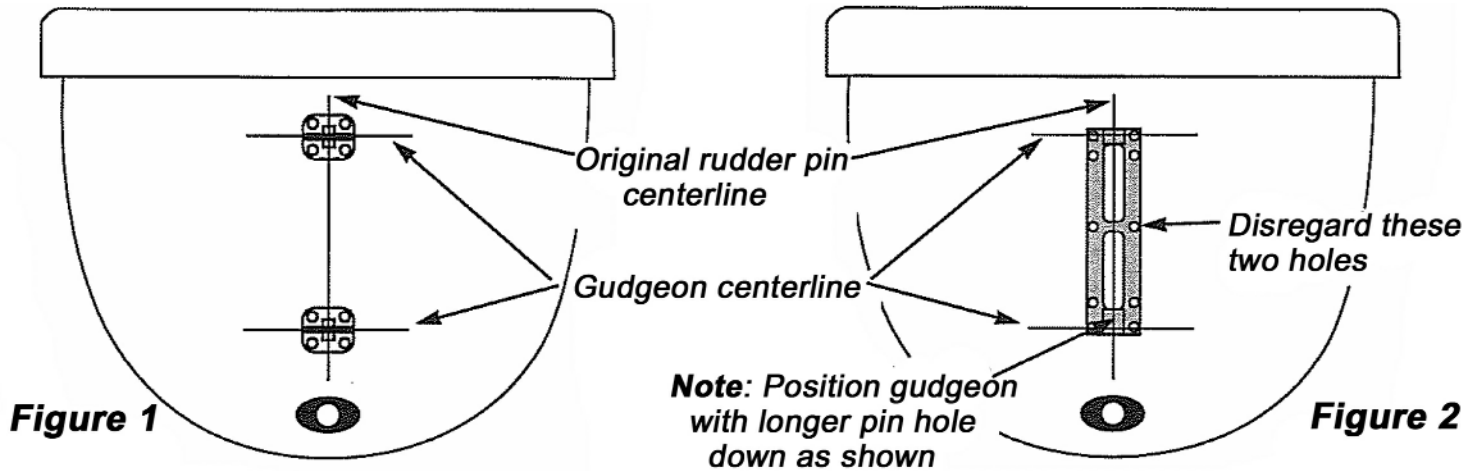

1) Mark the transom to show the original rudder pin centerline and the centerline of each gudgeon.

2) Carefully align the new gudgeon on the rudder pin centerline and vertically center the new gudgeon between the two horizontal marks that indicated the original gudgeon centerlines. Disregard the center two hole and mark the locations of the eight new holes. Drill with a #16 (.177) and tap with a #12-24 tap. Install the screws with silicone sealer around the threads.

3) The lower casting has to be filed to fit. Remove the material from the upper part of the lower portion of the casting. Approximates shown. File any sharp edges round and smooth. File the lower bushing to fit flush.

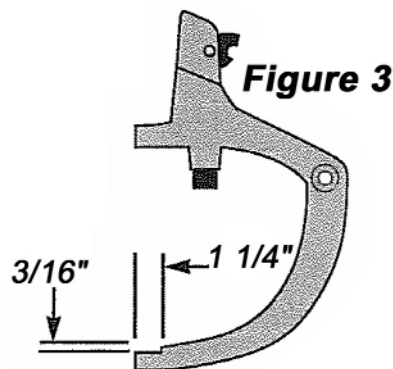

4) Assemble the parts in order as shown to the right. Install one cotter key in the rudder pin. Insert up through the lower bushing and casting, through cast gudgeon, through washer, through casting and bushing then install the second cotter key to hold the assembly captive. The washer must be on top of the gudgeon and between the gudgeon and the rudder casting to act as a bearing. The cotter keys the bushings captive *The additional washers are provided to shim the rudder pin and hold the bushing in tight if needed. Place these between the cotter keys and bushing heads if needed.

